



DESCRIPTION

The LSTH thermostat is a watertight, dust tight and corrosion resistant temperature control in a light-weight die cost enclosure with an internal calibrated reference dial and tamper-proof adjustment for outdoor or indoor locations. The liquid-filled thermal system, with its stainless steel bulb and capillary, provides a very dependable and accurate control system.

WIRING

For heater control, low alarm (close on falling temperature) use COM and NC. For high alarm (close on rising temperature) use COM and NO.

SPECIFICATIONS

Enclosure	Die cast aluminum with polyamid epoxy coating, NEMA 4X; watertight, dust tight and corrosion resistant
Connection	Screw terminals on switch through 1/2-NPT hub
Switch	SPDT UL listed with internal calibrated reference dial and tamper-proof adjustment
Rating	22 amps at 480 VAC
Range	25° - 325°F
Sensor	10 ft. 304 SS capillary with 1/8" SS bulb
Approval	UL listed/CSA certified
Accuracy	1% of adjustment range

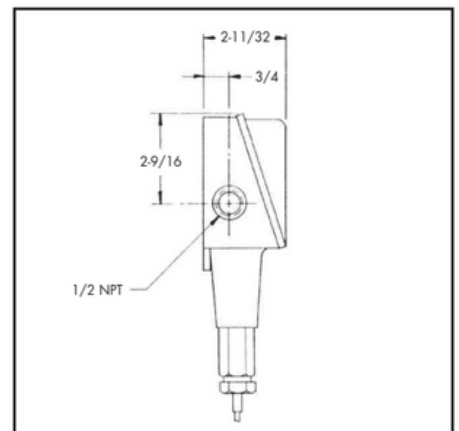
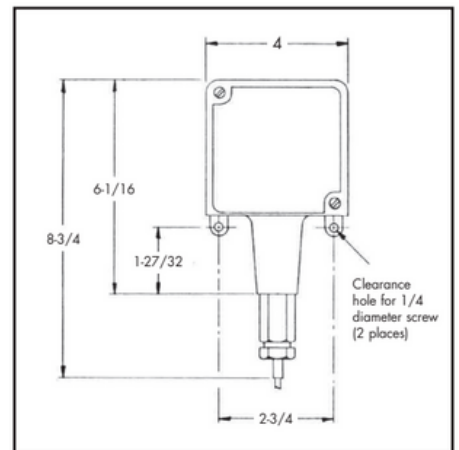

Typical installation for LSTH line sensing controller mounted on a pipe.

